

CM 201 SNAKE TRAY® SINGLE POCKET

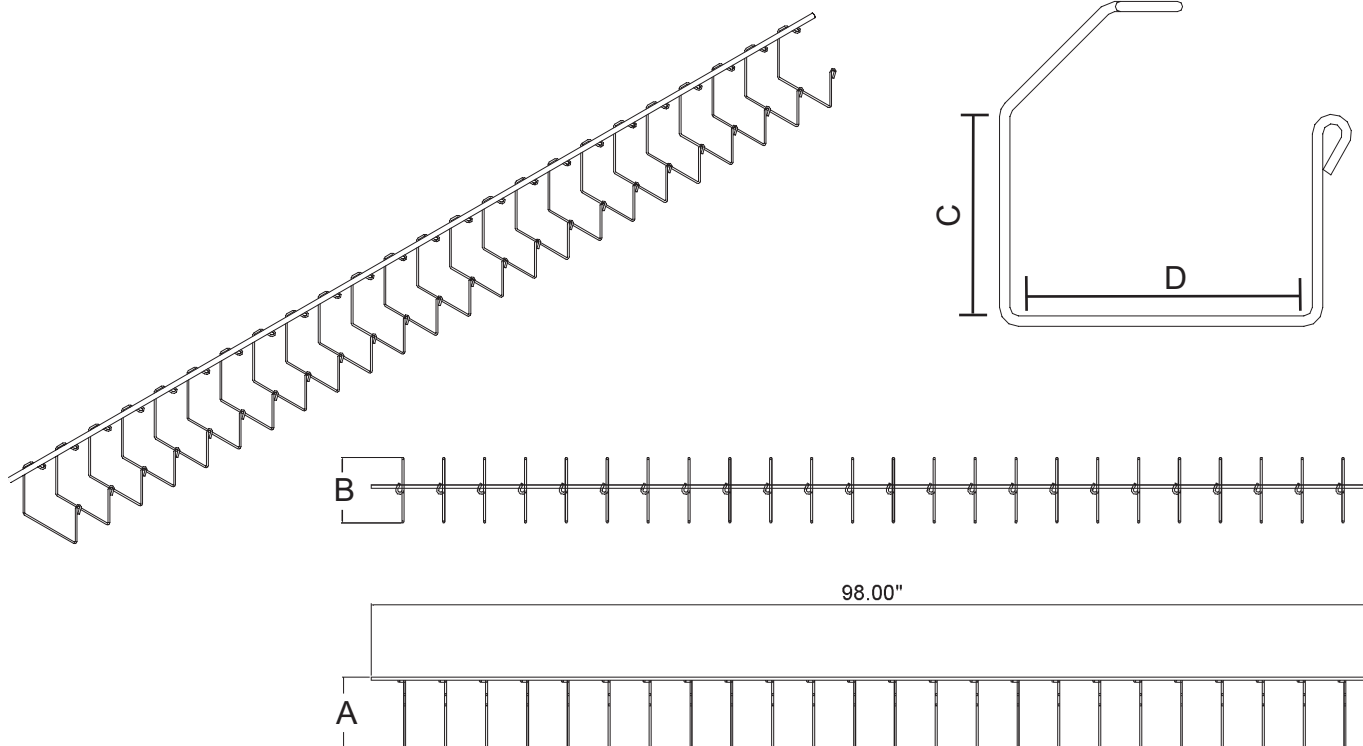

| Part No. | Physical Dimensions | | Loading Dimensions | | Cable Capacity | |
|--------------|---------------------|-----------|--------------------|-----------|-----------------|-----|
| | Height (A) | Width (B) | Depth (C) | Width (D) | Physical Volume | |
| CM-201-24-8 | 3" | 5" | 2" | 4" | 8si | 82 |
| CM-201-3-8 | 4 7/8" | 4" | 3" | 3" | 9si | 92 |
| CM-201-425-8 | 6 1/4" | 5 1/4" | 4 1/4" | 4 1/4" | 18si | 185 |
| CM-201-6-8 | 6 3/4" | 7" | 4" | 6" | 24si | 250 |

50% FILL AS PER NEC ARTICLE 392.9B
.25 OD

The 201 series Snake Tray is utilized both below raised floors and overhead either mounted to walls or suspended from the ceiling. Available in four sizes, the tray can accommodate up to 24 square inches of cable path, equal to a 12" generic basket or ladder type tray. Snake Eyes (mounting rings) are located along the center spine, allowing easy attachment of threaded rod for suspended applications.



Snake Tray® and Snake Canyon® products are covered by one or more of the following patents: #6,637,704, #6,637,165, #6,463,704, #6,460,812, #6,449,912, #6,361,000, #6,347,493, #6,019,323, #5,953,870, #5,839,702 and AUS #737,813. Other US and Foreign Patents Pending.

800-308-6788 • info@snaketray.com • www.snaketray.com